

INTRINSICALLY SAFE

EL232 XPCD

Explosion Proof Remote Serial Display



INDICATORS / CONTROLLERS



NOTE: Custom enclosures as requested. All explosion-proof devices are now built-to-order, so please coordinate purchase of these items with one of our application specialists.

Standard Features

- 20 mA current loop or RS-232 input
- Compatible with most Rice Lake indicators
- NEMA Type 4, 7CD, 9EFG enclosure

Part Number/Price

Part #	Description	Est. Weight	Price
20904	EL232 XPCD explosion proof remote serial display	25 lb	Consult

Dimensions

A	10.50 in (266.7 mm)	E	10.50 in (266.7 mm)
B	9.50 in (241.3 mm)	F	7.50 in (190.5 mm)
C	5.81 in (147.7 mm)	G	11.75 in (298.5 mm) (glass diameter)
D	11.75 in (298.5 mm)	H	7/16 in (11 mm) dia holes

CAUTION! The equipment contained within this Explosive Environment section requires greater attention to specification and installation guidelines. Improper specification, installation or service of these products can result in loss of equipment or serious injury.

Specifications

Display:

High-intensity, red LED, 0.8 in (20.3 mm) high digits

Input Voltage:

115 VAC, 60 Hz

Weight:

Approximately 25 lb (11.3 kg)

NEC Classifications:

Class I, Division 1, Groups C & D; Class II, Division 1, Groups E, F & G and Class III hazardous environments

Baud Rate:

1200, 2400, 4800 and 9600

Interfaces:

20 mA current loop and RS-232 please consult factory for model numbers and interface requirements

Warranty:

One-year limited warranty

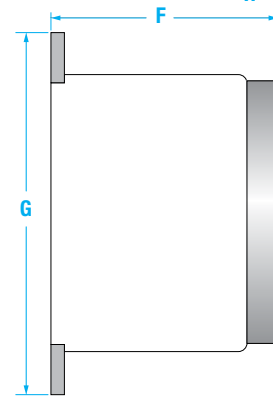
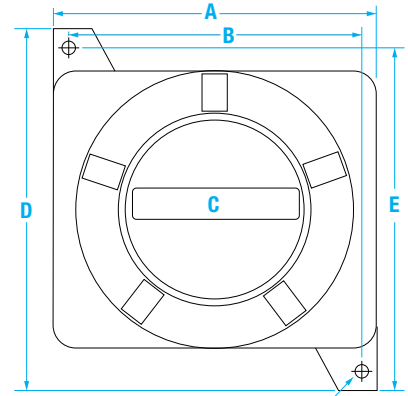

www.weigh-tech.com | Phone: (281) 474-5277

